

48" Type 2 Precast Catch Basin

WSDOT B-10.20-00

Flat-top Slab Reinforcing

- #4 deformed rebar
- Round or rectangular opening

Manhole Wall Reinforcing

- Minimum 0.120 square inches / linear foot

Base Reinforcing

- 0.15 square inches / linear foot in both directions
-  Separated base slab 0.23 square inches / linear foot in both directions

Hole or Knock Out Dimensions

- Maximum hole size is 36 inches
- 8 inches of minimum distance between holes
- 2 inch diameter lifting holes provide
- Cored holes available

Conformity Standards

- ASTM C478 - 97 Manhole
- ASTM C443 rubber gasket joint
- ASTM D - 4101 polypropylene steps and ladders
- Washington State APWA / WSDOT Standard

Options Available

- 2 foot minimum sump
- Specialized coatings
- Custom hatches
- Kor-N-Seal boots

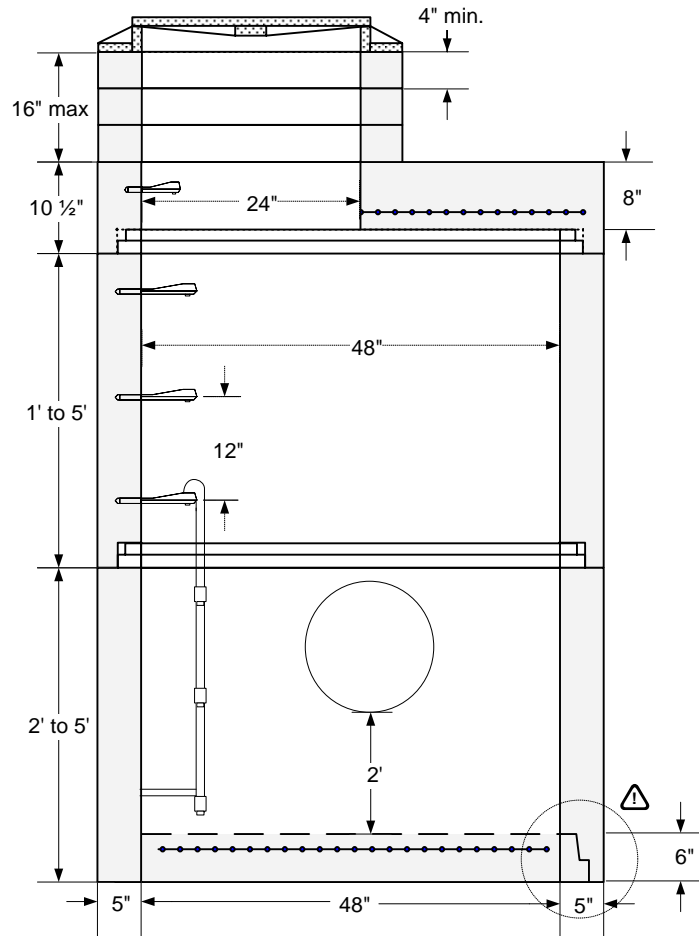

Top Slab Plan View

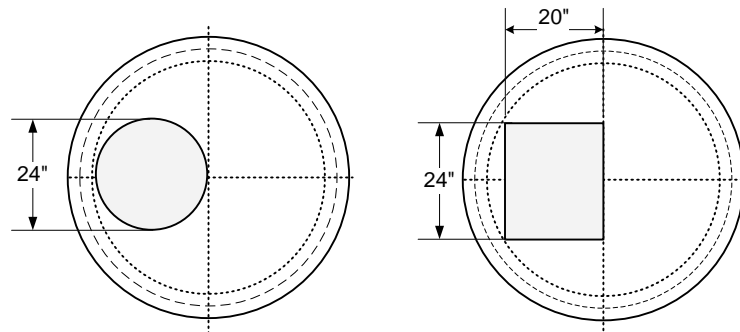

Note: drawings not to scale